

L. L. HILL.  
WOOD TURNING LATHE.

No. 491,941.

Patented Feb. 14, 1893.

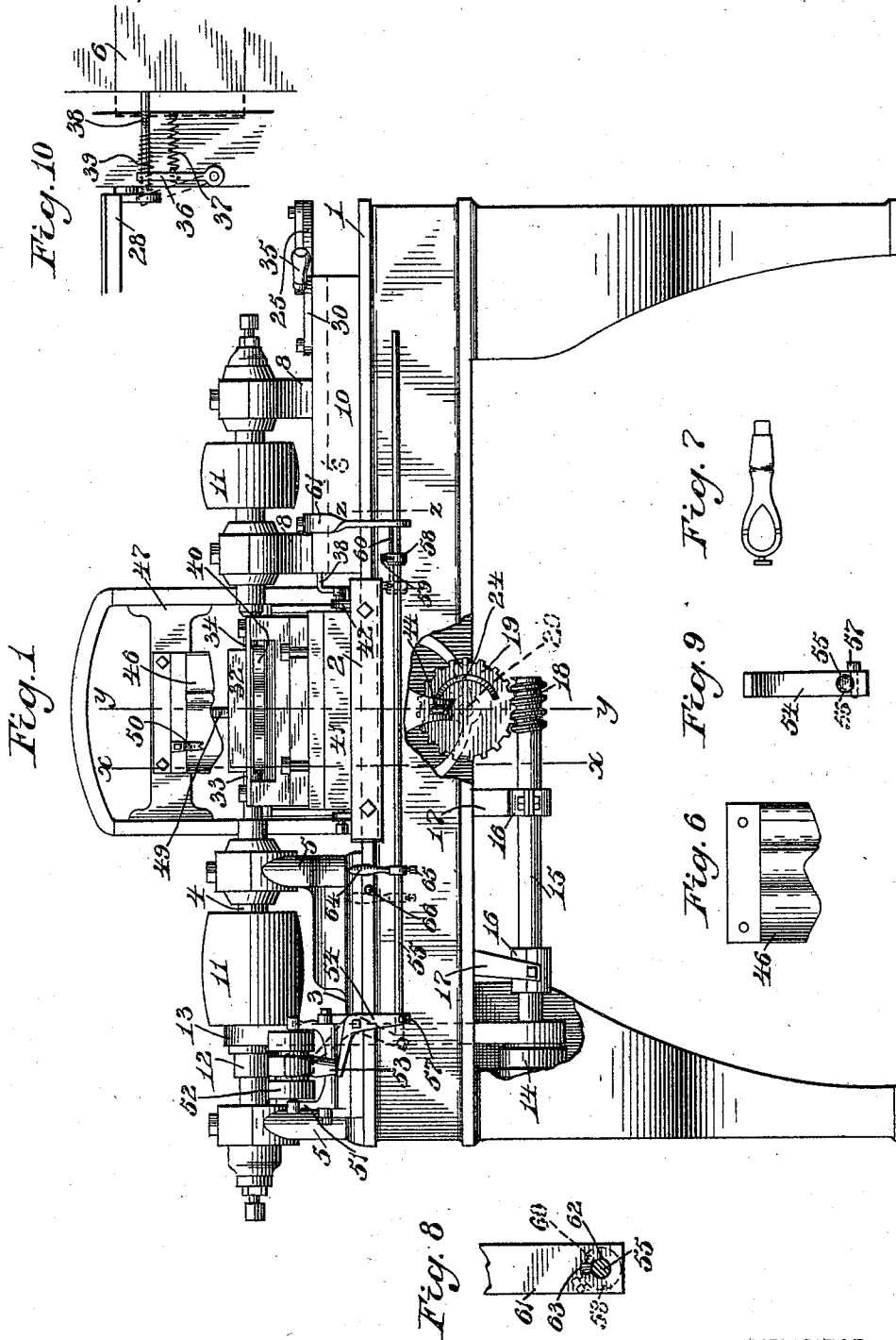

WITNESSES  
 E. M. Hallahan  
 M. A. Huggard

INVENTOR  
 Lyman L. Hill  
 By A. M. Wooster  
 Att.

L. L. HILL.  
WOOD TURNING LATHE.

No. 491,941.

Patented Feb. 14, 1893.

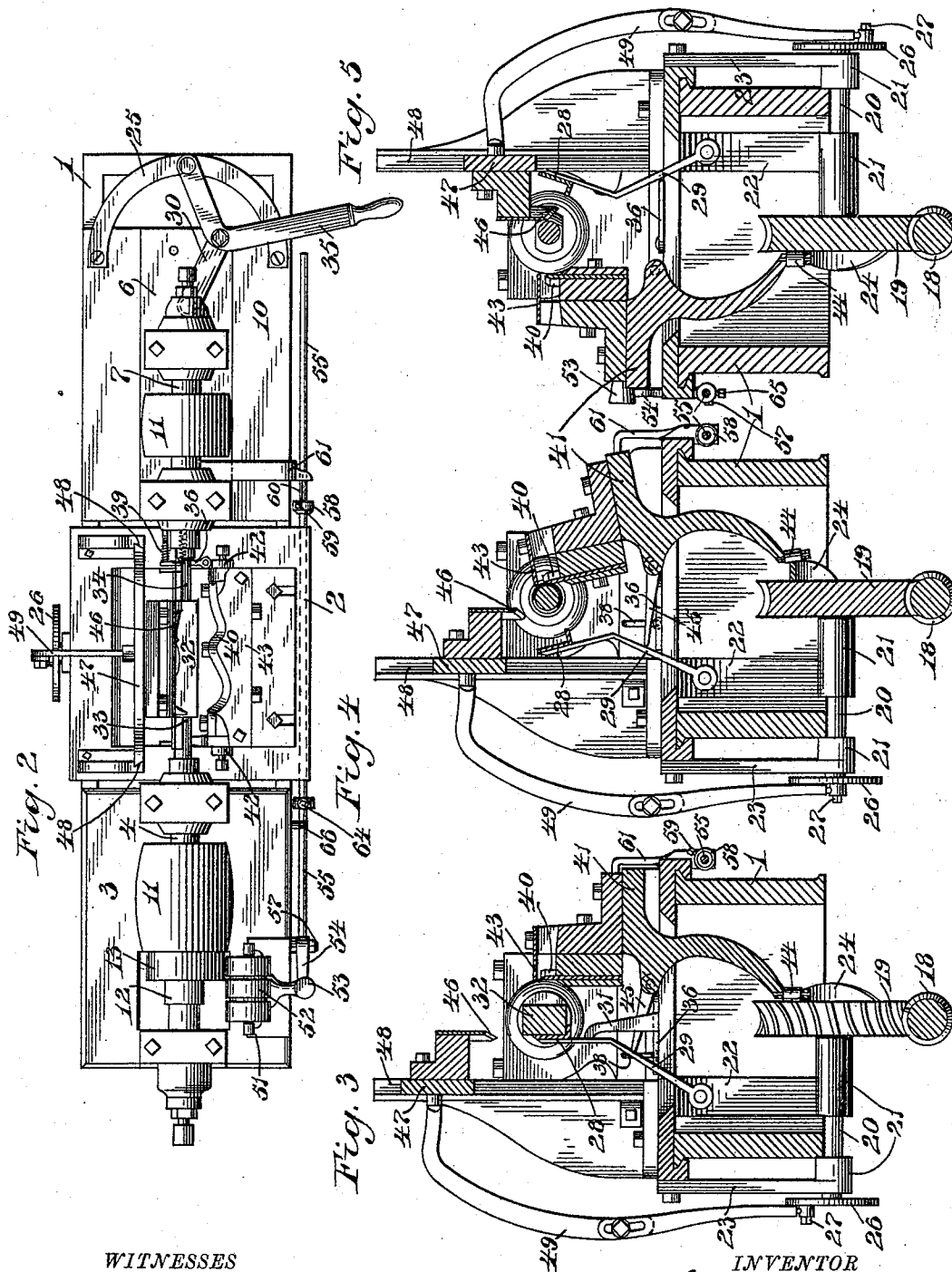

WITNESSES

*E. M. Hallahan*  
*M. A. Huggard*

INVENTOR

*Lyman S. Hill*  
*J. A. Wooster atty.*

# UNITED STATES PATENT OFFICE.

LYMAN L. HILL, OF BRIDGEPORT, CONNECTICUT, ASSIGNOR TO HENRY C. BRADLEY, OF SAME PLACE.

## WOOD-TURNING LATHE.

SPECIFICATION forming part of Letters Patent No. 491,941, dated February 14, 1893.

Application filed August 27, 1891. Serial No. 403,882. (No model.)

*To all whom it may concern:*

Be it known that I, LYMAN L. HILL, a citizen of the United States, residing at Bridgeport, in the county of Fairfield and State of Connecticut, have invented certain new and useful Improvements in Wood - Turning Lathes; and I do hereby declare the following to be a full, clear, and exact description of the invention, such as will enable others skilled in the art to which it appertains to make and use the same.

My invention relates to the class of lathes illustrated and described in Patent No. 377,617, granted to me February 7, 1888, and has for its object to still further improve and perfect the operation of the machine, its manipulation by the operator being very much simplified in my present machine, thereby increasing its speed in use.

With this end in view I have improved the details of construction in the manner which I will now describe in connection with the accompanying drawings forming part of this specification, in which,

Figure 1 is a side elevation of the lathe complete, a portion of the bed being broken away; Fig. 2, a plan view; Fig. 3, a cross section on an enlarged scale on the line *xx* in Fig. 1 looking toward the right, showing the position of the parts after a block has been placed in position on the centering rest ready to be acted upon; Fig. 4, a cross section on the line *yy* in Fig. 1 looking toward the right, showing the position of the parts at the completion of the action of the first cutter; Fig. 5, a cross section on the line *yy* in Fig. 1 looking toward the left, the parts being in the position they occupy at the completion of the action of the second cutter; Fig. 6, an elevation of the second cutter detached; Fig. 7, an elevation of a completed tool handle corresponding in outline with the cutters illustrated; Fig. 8, a detail cross section on the line *zz* in Fig. 1 looking toward the left; Fig. 9, a detail end elevation of the operating rod and bell crank lever which operates the belt tightening mechanism, and, Fig. 10 is a detail plan view of the mechanism for holding the centering rest out of operative position.

1 denotes the bed; 2, the saddle; 3, the stationary head stock; 4, the stationary head stock spindle journaled in brackets 5. 6, the movable head stock; 7, the movable head stock spindle journaled in brackets 8; and 10, a block upon the bed having ways in which the movable head stock slides. Rotary movement is imparted to spindles 4 and 7 by belts, not shown, which pass over pulleys 11 on said spindles.

12 denotes a cone pulley on spindle 4, and 13 a belt connecting said pulley with a cone pulley 14 placed inversely thereto on a shaft 15 beneath the bed. This arrangement enables me to change the speed of shaft 15 relatively to the speed of the spindles. This shaft is journaled in boxes 16 upon brackets 17 secured to the bed. At the inner end of shaft 15 is a worm 18 which engages a wheel 19 on a shaft 20 journaled in bearings 21 supported by brackets 22 and 23 secured to the saddle. Upon the outer face of worm wheel 19 is a cam 24. At the outer end of shaft 20 is a disk 26 having a crank pin 27. The function of these parts will presently be described in full.

28 denotes a centering rest carried by an arm 29 which is pivoted to bracket 22. The special shape of this centering rest is not of the essence of my invention. As handles and other small articles of this class are usually turned from rectangular blocks of wood the back and bottom of the rest are usually at right angles to each other as shown in the drawings. It will be noticed (see Figs. 3 and 4) that the pivotal point of arm 29 is outside of a vertical line extending downward from the centering rest at any position it can assume, the tendency being to throw it toward the operative position at all times, in which position it will remain until removed therefrom in the manner presently to be described.

31 is a stop projecting upward from the saddle which acts to limit the forward movement of the rest so that it is always stopped when just in operative position. The block to be operated upon which I have indicated by 32 is placed upon the centering rest, one end thereof lying in contact with the chuck 33 of

the stationary head stock. The chuck 34 of the sliding head stock is then moved against the other end of the block by means of an L-shaped hand lever 35, the inner end of which is pivoted to a bracket 25 extending outward from block 10.

30 denotes a link one end of which is pivoted to the movable head stock the other being pivoted to the angular portion of lever 35. In Fig. 2 I have shown a block as just engaged by the chucks. It is obvious that further movement of the hand lever toward the left will cause the block to be firmly clamped and held by the chucks. As soon as motion is communicated to the head stocks and chucks, the block will be rotated thereby and will act to throw the centering rest backward out of the way. In order to hold the rest out of the way during the operation of turning I provide a swinging holder 36 which is pivoted to the bed and is held at its retracted position that is out of operative position by a suitable spring 37, in the drawings I have shown a coil spring one end of which is connected to the swinging holder, the other to the bed.

38 denotes a rod which projects inward from the movable head stock and is bent downward and inward again so as to engage swinging holder 36 and move it forward in position to engage the centering rest and hold it out of operative position as indicated by dotted lines in Fig. 10. At the engaging end of rod 38 I place a coil spring 39 which extends forward from the end of the rod and is compressed by the forward movement of the rod as soon as it strikes the swinging holder serving as a buffer to prevent violent contact of the rod therewith, (see Figs. 2 and 10.) As soon as the forward movement of the slide commences rod 38 moves forward with it and spring 39 engages the swinging holder and is compressed thereby until the movement of the centering rest which has just been described takes place. As soon as the centering rest flies backward out of the way spring 39 acts instantly to throw the swinging holder inward in front of it as shown in dotted lines in Fig. 10 and to hold it there, it being of course understood that spring 39 is stronger than spring 37, it being simply necessary that spring 37 shall be strong enough to draw the swinging holder backward out of the way as soon as the pressure of rod 38 and spring 39 is relieved.

Any other form of spring may be substituted for the form shown in the drawings, but little power being required to return the swinging holder to its normal position when the pressure of spring 39 and the rod is removed by the backward movement of the movable head stock. In use the head stocks and chucks are continuously in motion. The operation of the cutters is precisely the same as in my said former patent referred to.

40 denotes the first or roughing cutter which is adjustably secured to a swinging rest 41 pivoted to ears 42 on the saddle.

43 is a guard which rests against the block to be operated upon and prevents the cutter from making too deep a cut. The swinging rest extends downward through an aperture in the saddle and its lower end engages cam 24 on the worm wheel.

44 denotes a roller which I preferably use as a contact surface for the rest upon the cam. The operation of this cam is to swing the rest in and out, thus throwing the roughing cutter into and out of operative position.

45 is a stump projecting backward from the swinging rest which comes in contact with the centering rest after it has been thrown out of operative position by the rotation of the block that is being operated upon. This stump insures the holding of the swinging rest out of the way during the operation of the second or finishing cutter which I will presently describe. If for any reason the swinging holder should fail to act and the swinging rest move forward during the operation of the finishing cutter, it is obvious that the cutter would become quickly ruined. Stump 45, however, insures that the swinging rest shall be held out of the way during the entire operation of the finishing cutter.

46 denotes the finishing cutter which is carried by slide 47 moving in ways 48. The line of movement of this cutter is precisely the same as in my said former patent referred to. Motion is imparted to slide 47 by means of an adjustable rod 49, one end of which is pivoted to the slide, the other to crank pin 27 on disk 26. The operation of the crank pin and cam are so timed as to bring the second cutter into operation the instant after the action of the first cutter is finished.

50 denotes a supplementary cutter secured to the slide by means of which the ordinary or any required ornamental lines may be placed upon the handle.

In use belt 13 which runs over cone pulleys 12 and 14 is left so loose that shaft 15 will not be carried until the belt is tightened. The tightening of the belt is accomplished by means of a swinging tightener 51 carrying a roller or rollers 52 which engage the belt.

53 denotes a weight upon the swinging tightener the action of which is to throw the tightener out of operative position. The tightener is swung into operative position to tighten the belt by means of a bell crank lever 54 pivoted to the stationary head stock, one arm of said lever lying under the weight and acting to tilt the tightener when the bell crank lever is oscillated.

In order to simplify the operation of the machine so that a single movement will stop or start the entire machine, I provide a sliding rod 55 one end of which is connected to the bell crank lever and the other to the movable head stock so as to be operated by lever 35. As it is necessary that rod 55 should have oscillatory movement in the bell crank lever, I preferably connect said parts together in

the manner illustrated in Fig. 9. Rod 55 which passes loosely through an opening in the bell crank lever is provided with a groove 56, see dotted lines Fig. 9. A set screw, 57 passes through the bell crank lever a portion of the body of the screw lying in the groove in rod 55, thus locking the bell crank lever and rod together so that longitudinal movement of the rod will oscillate the bell crank lever, at the same time leaving the rod free to oscillate in the lever.

58 denotes a collar on rod 55 which is locked thereto by a set screw 59, and 60 is a rod projecting outward from the collar.

61 denotes a guide which is rigidly secured to the movable head stock, the end thereof extending downward outside of the body and being provided with an opening 62 through which rod 55 passes freely and with another opening 63 which is adapted to receive rod 60 when rod 55 and the collar are oscillated.

64 denotes a hand piece which is locked to rod 55 by a set screw 65, and 66 a suitable stump or projection on the edge of the bed which is engaged by the hand piece to hold the swinging tightener in operative position so that the motion of the pulley 12 on the spindle of the stationary head stock will be communicated by the belt to pulley 14 on shaft 15. It will thus be seen that in my present lathe after having placed the block in position on the centering rest, the operator is required to make but a single movement, to wit, the inward movement of lever 35 and then, at the completion of the turning of the handle, an outward movement, said lever 35 acting by means of the connections already described to clamp the block between the chucks which are continuously in rotation,

and also by means of rod 55 the belt tightener &c. transmitting movement to shaft 15 from which the cutters are operated. In practice the skilled operator usually prefers to loosen set screws 59 and move the collar far enough toward the left on shaft 55 so that when the movable head stock is moved toward the left guide 61 will slide freely toward and over rod 55, but without moving it the slightest, and in order that the movement of the cutters shall be continuous that is to say that there be no stoppage in the movements of the cutters after they have finished the handle, the skilled operator moves rod 55 forward to a position which oscillates the bell crank lever and swings the belt tightener into operative position and then locks it there by engaging the hand piece with stump 66 allowing the parts to remain in this position as long as may be required. When the lathe is operated in this manner, the operator feeds the blocks with one hand and operates lever 35 with the other, it being necessary of course to operate lever 35 to release the handle as soon as it is completed, then to place a new block between the chucks and to operate lever 35 again without delay,

so as to have the new block in position to be operated upon by the roughing cutter as soon as it is moved into operative position in the manner just described.

When the operator does not desire to have the operation of the cutters continuous, hand piece 64 is not engaged with the stump and collar 58 is adjusted in such a position that when the guide moves forward with the movable head stock, it will engage the end of rod 60, and will carry rod 55 forward to operate the bell crank lever and belt tightener each time the chucks are operated, it necessarily following that if the chucks are not operated, the belt tightener will not be operated, and motion will not be imparted to the cutters. When the machine is being used in this manner, should it be required to stop the motion of the cutters quickly at any time the operator grasps the hand piece and oscillates rod 55 forward until rod 60 registers with opening 63 in the guide. The weight will now act to swing the bell crank lever to the position shown in Fig. 1 which will relieve the pressure upon the belt instantly and will stop the rotation of shaft 15 and consequently the movement of the cutters. The movement of the cutters may be stopped in the same manner should it be necessary when they are being used continuously that is to say not stopped and started each time a block is put in. The operator in this case simply disengages the hand piece from the stump and moves rod 55 toward the right. There will be in this instance no engagement of rod 60 with opening 63 as the collar will have been moved far enough toward the left on rod 55 to place rod 60 out of operative position.

Having thus described my invention, I claim—

1. In a lathe, the combination with a movable head-stock, of a swinging cutter holder, a shaft for operating said holder, a belt for driving said shaft, a swinging belt tightener, a crank lever connected with said tightener, a rod 55 loosely connected with the lever, an arm 61 secured to the movable head stock, and having an eye receiving the rod 55, and suitable intermediate connections whereby the rod is carried forward when the head stock is moved inward, substantially as described.

2. In a lathe, the combination with the movable and stationary head stocks, the centering rest and the cutters, of swinging tightener 51, bell crank lever 54 having an opening, rod 55 passing loosely through said opening and having a groove, a set screw engaging the lever and groove, movable guide 61 having an opening through which rod 55 passes and an opening 63, and a collar on rod 55 having a rod 60 adapted to engage opening 63 when the rod is oscillated.

3. In a lathe, the combination with the movable and stationary head stocks, the center-

ing rest and the cutters, of stump 66, guide 61 having openings 62 and 63, the swinging tightener and the bell crank lever, rod 55 loosely connected to said lever and passing 5 through opening 62 in the guide, collar 58 having a rod 60, and hand piece 64 upon the rod which is adapted to engage stump 66 to hold the parts in operative position and to oscillate rod 55 so that rod 60 will enter open-

ing 63 when it is desired to stop the action of the cutters.

In testimony whereof I affix my signature in presence of two witnesses.

LYMAN L. HILL.

Witnesses:

A. M. WOOSTER,  
NELLIE A. FRAWLEY.